



Ventiltechnik

Produktkatalog

Rückschlagarmaturen

Version: 07 / 10

5. Rückschlagarmaturen

5.1. Allgemein Rückschlagarmaturen

Bei Rückschlagarmaturen wird die gewünschte Bewegung durch das Medium in der Rohrleitung erzeugt. Unterschieden wird zwischen Rückschlagventilen und Rückschlagklappen. Bei federbelasteten Rückschlagarmaturen wird ein für den Anwendungsfall einzusetzendes Absperrerelement in einer Richtung durch eine Feder zum Durchgang hin geschlossen, in der Gegenrichtung wird der Durchgang vom strömenden Medium freigegeben.

Produktionsprogramm

Typ	Art	DN	PN
RSV 16	Rückschlagventil	15 bis 300	16 bis 320*
RSK 10	Rückschlagklappe	50 bis 300	63 bis 320*

* Andere Druckstufen und Nennweiten auf Anfrage

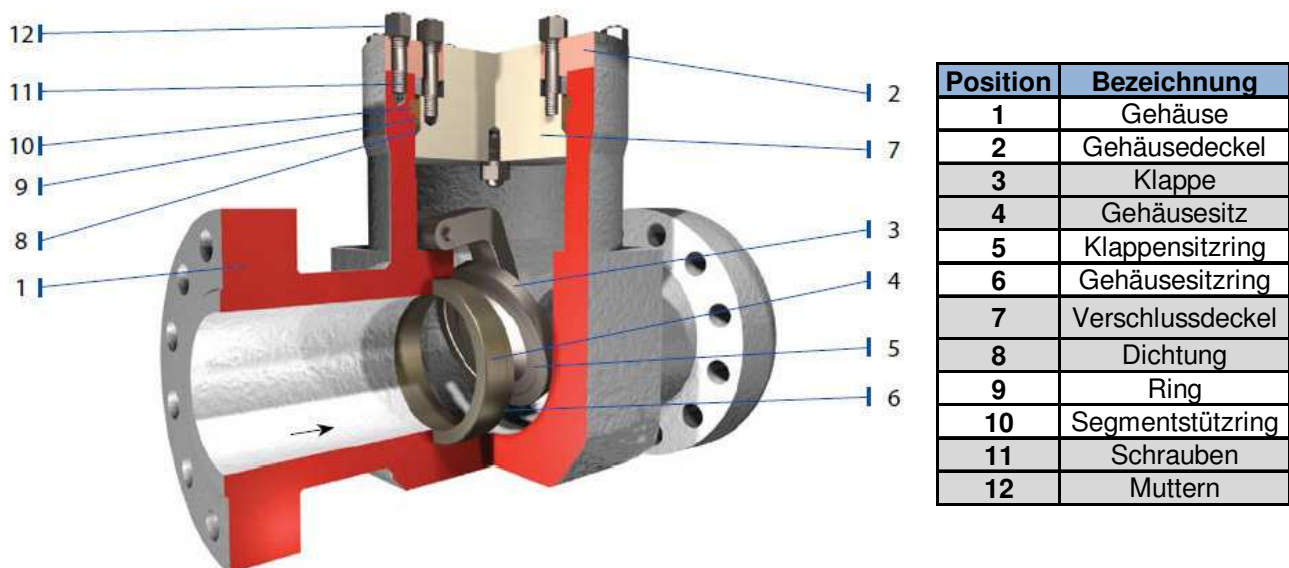

5.2. Rückschlagventil Typ: RSV16 PN 16 – PN 100

Produktmerkmale

- Federbelastetes Rückschlagventil
- Metallisch dichtend und weichdichtend (PN 63 und PN 100)
- Flanschanschluss nach EN 1092-1, GOST 12815- 80
- Anschweissenden nach EN 12627
- Flanschbaulänge nach EN 558
Grundreihe: 1 (PN16 – PN 40),
Grundreihe: 2 (PN 63 – PN 100)
- Druckprüfung nach EN 12266-1
- Abnahmeprüfzeugnis nach EN 10204- 3.1

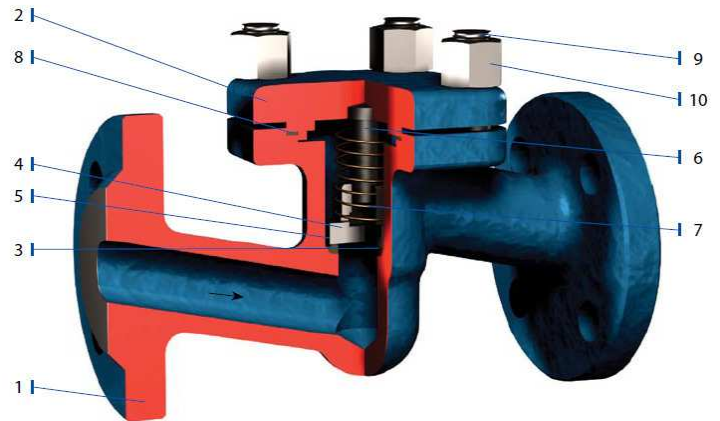

Position	Bezeichnung
1	Gehäuse
2	Gehäusedeckel
3	Gehäusesitz
4	Kegel
5	Kegelsitz
7	Rückstellfeder
8	Dichtung
9	Schraube
10	Mutter

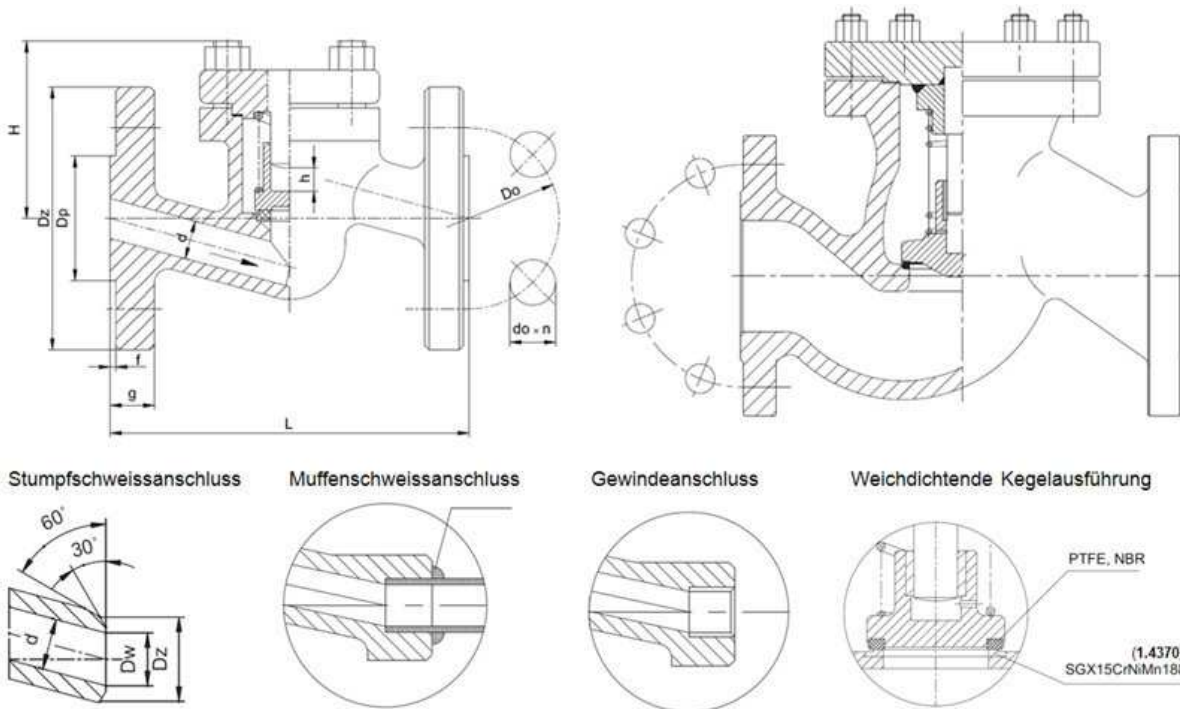

Bezeichnung	Material PN 16 - PN 40			
	DN 15- DN 50		DN 65- DN 300	
Gehäuse	X6CrNiTi18-10 (1.4541)	X2CrNiMo17-12-2 (1.4404)	GX5CrNi19-10 (1.4308)	GX5CrNiMo19-11-2 (1.4408)
Gehäusedeckel				
Kegel	X6CrNiTi18-10 (1.4541)	X2CrNiMo17-12-2 (1.4404)	X6CrNiTi18-10 (1.4541)	X2CrNiMo17-12-2 (1.4404)
Rückstellfeder	X6CrNiTi18-10 (1.4541)			
Dichtung	Graphit			

Bezeichnung	Material PN 16 - PN 40			
	T _{max} 450 °C	T _{max} 530 °C	T _{max} 450 °C	T _{max} 530 °C
	DN 15- DN 50		DN 65- DN 300	
Gehäuse	P250GH (1.0460)	16Mo3 (1.5415)	GP240GH (1.0619)	G20Mo5 (1.5419)
Gehäusedeckel				
Gehäusesitz	X15CrNiMn18-8 (1.4370), Stellite			
Kegel	X30Cr13 (1.4028), X17CrNi16-2 (1.4057), P250GH (1.0460) oder 13CrMo4-5 (1.7335)			
Kegelsitz	X15CrNiMn18-8 (1.4370), Stellite, PTFE, NBR			
Rückstellfeder	51CrMoV4 (1.2241)			
Dichtung	Graphit			

Bezeichnung	Material PN 63 - PN 100					
	T _{max} 450°C	T _{max} 530°C	T _{max} 560°C	T _{max} 450°C	T _{max} 530°C	T _{max} 550°C
	DN 15- DN40			DN 50- DN 200		
Gehäuse	P250GH	16Mo3	13CrMo4-5	GP240GH	G20Mo5	G17CrMo5-5
Gehäusedeckel	(1.0460)	(1.5415)	(1.7335)	(1.0619)	(1.5419)	(1.7357)
Gehäusesitz	X15CrNiMn18-8 (1.4370) oder Stellite 6					
Kegel	X30Cr13 (1.4028), X17CrNi16-2 (1.4057), P250GH (1.0460) oder 13CrMo4-5 (1.7335)					
Kegelsitz	X15CrNiMn18-8 (1.4370), Stellite 6, PTFE oder NBR					
Rückstellfeder	51CrMoV4 (1.2241)					
Dichtung	Graphit+ Edelstahl					

Flanschanschluss													Anschweissenden		
PN	DN	L	Dz	Do	Dp	g	f	Dk	h	H	do x n	Gewicht [kg]	Dz	Dw	Gewicht [kg]
16	15	130	95	65	45	16	2	120	10	65	14 x 4	2,5	22	18	1,1
	20	150	105	75	58	18	2	120	10	65	14 x 4	2,9	27	23	1,4
	25	160	115	85	68	18	2	120	10	65	14 x 4	3,3	34	29	1,7
	32	180	140	100	78	18	2	160	15	85	18 x 4	6,8	43	37	3,6
	40	200	150	110	88	18	3	160	17	95	18 x 4	9,0	49	43	4,7
	50	230	165	125	102	20	3	160	21	110	18 x 4	10,5	61	55	6,1
	65	290	185	145	122	22	3	200	22	155	18x4 od. 18 x 8	17,5	77	69	12,7
	80	310	200	160	138	24	3	250	26	170	18 x 8	27,0	90	81	18,5
	100	350	220	180	158	24	3	320	32	195	18 x 8	41,0	115	105	36,0
	125	400	250	210	184	26	3	280	40	200	18 x 8	54,0	141	131	49,0
	150	480	285	240	212	28	3	320	44	225	22 x 8	90,0	170	158	76,0
	200	600	340	295	268	34	3	400	60	270	22 x 12	150,0	222	204	140,0
250	730	405	355	320	38	3	400	70	290	26 x 12	195,0	290	260	165,0	
300	850	460	410	370	42	3	600	130	410	26 x 12	360,0	350	315	280,0	

Flanschanschluss													Anschweissenden		
PN	DN	L	Dz	Do	Dp	g	f	Dk	h	H	do x n	Gewicht [kg]	Dz	Dw	Gewicht [kg]
40	DN 15 - DN 80 siehe Anschlussmaße PN 16														
	100	350	235	190	162	24	3	320	32	195	22 x 8	41,0	115	105	36,0
	125	400	270	220	188	26	3	280	40	200	26 x 8	54,0	141	131	49,0
	150	480	300	250	218	28	3	320	44	225	26 x 8	90,0	170	158	76,0
	200	600	375	320	285	34	3	400	60	270	30 x 12	150,0	222	204	140,0
	250	730	450	385	345	38	3	400	70	290	33 x 12	195,0	290	260	165,0
300	850	515	450	410	42	3	600	130	410	33 x 16	360,0	350	315	280,0	

PN	DN	d	H	h	Flanschanschluss									Anschweissenden			
					Dz	Dp	Do	do	n	L	g	f	kg	Dz	Dw	L	kg
63 100	15	14	70	13	105	45	75	14	4	210	20	2	4,0	22	15,5	160	2,7
	20	19	75	13	130	58	90	18	4	230	22	2	6,2	27	20,5	160	2,7
	25	23	75	13	140	68	100	18	4	230	24	2	8,3	34	26,5	160	2,7
	32	30	95	16	155	78	110	22	4	260	24	2	11,5	43	35	230	5,2
	40	38	95	18	170	88	125	22	4	260	28	3	14,8	49	41	230	7,7
63	50	45	140	22	180	102	135	22	4	300	26	3	15,7	57	51,2	300	12,9
	65	62	170	30	205	122	160	22	8	340	26	3	37,5	77	65	340	26,3
	80	73	195	40	215	138	170	22	8	380	28	3	40,3	89	78	380	27,5
	100	94	200	55	250	162	200	22	8	430	30	3	54,0	115	104	430	37,2
	125	120	225	65	295	188	240	26	8	500	34	3	76,0	141	127	500	48,9
	150	144	300	70	345	218	280	33	8	550	36	3	151,0	170	158	550	101,1
	200	195	400	100	415	285	345	36	12	650	42	3	215,0	265	215	650	135,0
100	50	45	140	22	195	102	145	26	4	300	28	3	15,7	57	51,2	300	12,9
	65	62	170	30	220	122	170	26	8	340	30	3	37,5	77	65	340	26,3
	80	73	195	40	230	138	180	26	8	380	32	3	40,3	89	78	380	27,5
	100	94	200	55	265	162	210	30	8	430	36	3	54,0	115	104	430	37,2
	125	120	225	65	315	188	250	33	8	500	40	3	76,0	141	127	500	48,9
	150	144	300	70	355	218	290	33	12	550	44	3	151,0	170	158	550	101,1
	200	195	400	100	430	285	360	36	12	650	52	3	215,0	275	215	650	135,0

5.3. Rückschlagventil Typ: RSV16 PN 160

Produktmerkmale

- Federbelastetes Rückschlagventil
- Metallisch dichtend
- Flanschanschluss nach EN 1092-1, GOST 12815- 80
- Anschweissenden nach EN 12627
- Flanschbaulänge nach EN 558 Grundreihe: 2
- Druckprüfung nach EN 12266-1
- Abnahmeprüfzeugnis nach EN 10204- 3.1

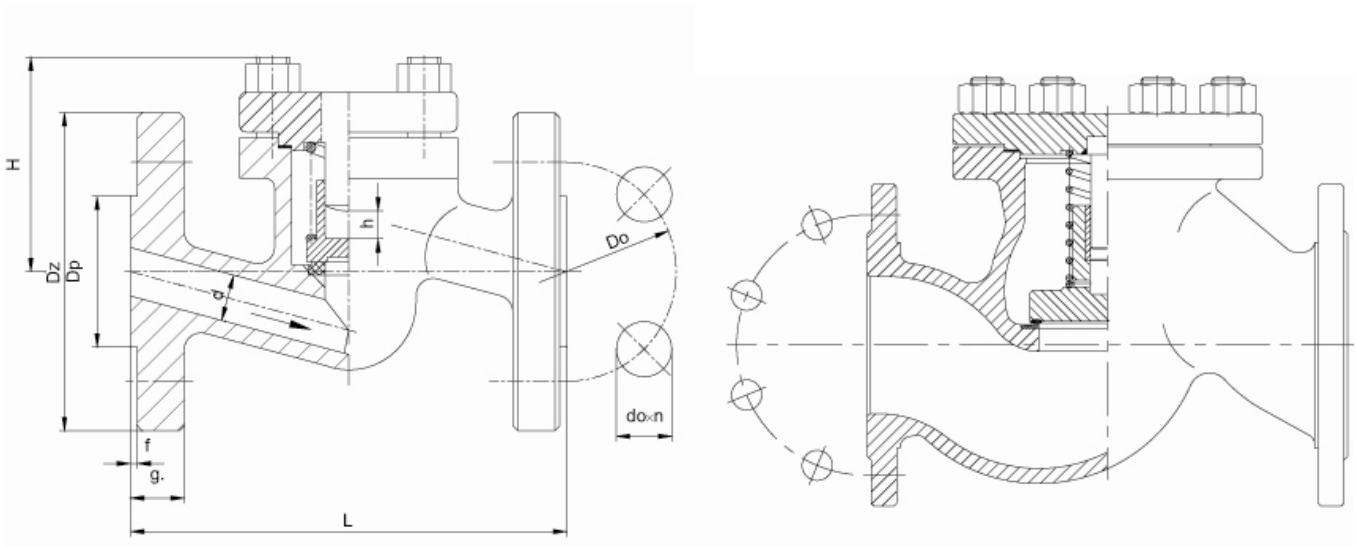

Stumpfschweissanschluss

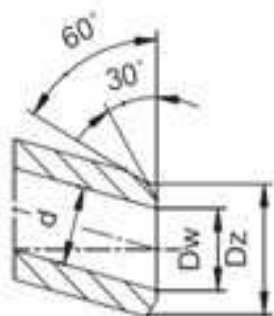

Muffenschweissanschluss

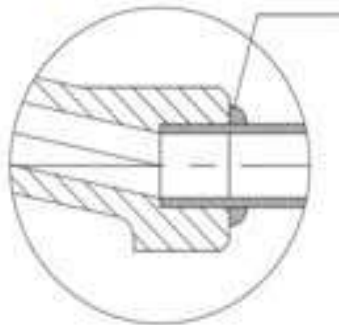

Gewindeanschluss

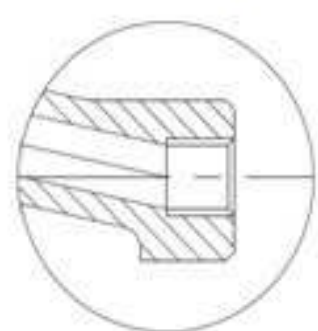

Bezeichnung	Material PN 160					
	T _{max} 450 °C	T _{max} 530 °C	T _{max} 560 °C	T _{max} 450 °C	T _{max} 530 °C	T _{max} 550 °C
	DN 15- DN40			DN 50- DN 200		
Gehäuse	P250GH	16Mo3	13CrMo4-5	GP240GH	G20Mo5	G17CrMo5-5
Gehäusedeckel	(1.0460)	(1.5415)	(1.7335)	(1.0619)	(1.5419)	(1.7357)
Gehäusesitz	X15CrNiMn18-8 (1.4370) oder Stellite 6					
Kegel	X30Cr13 (1.4028), X17CrNi16-2 (1.4057), P250GH (1.0460) oder 13CrMo4-5 (1.7335)					
Kegelsitz	X15CrNiMn18-8 (1.4370) oder Stellite 6					
Rückstellfeder	51CrMoV4 (1.2241)					
Dichtung	Graphit+ Edelstahl					

PN	DN	d	H	h	Flanschanschluss								Anschweissenden				
					Dz	Dp	Do	do	n	L	g	f	kg	Dz	Dw	L	kg
160	15	14	70	13	105	45	75	14	4	210	20	2	4,0	22	17,3	160	2,7
	20	19	75	13	130	58	90	18	4	230	22	2	6,2	28	21,7	160	2,7
	25	23	75	13	140	68	100	18	4	230	24	2	8,3	34	27	160	2,7
	32	30	95	16	155	78	110	22	4	260	24	2	11,5	43	34	230	5,2
	40	38	95	18	170	88	125	22	4	260	28	3	14,8	51	42	230	7,7
	50	45	140	22	195	102	145	30	4	300	30	3	15,7	61	50,5	300	12,9
	65	62	170	30	220	122	170	26	8	340	34	3	37,5	77	64	340	26,3
	80	73	195	40	230	138	180	26	8	380	36	3	40,3	90	75	380	27,5
	100	94	200	55	265	162	210	30	8	430	40	3	54,0	115	98	430	37,2
	125	120	225	95	315	188	250	33	8	500	44	3	76,0	141	120	500	48,9
	150	144	300	100	355	218	290	33	12	550	50	3	151,0	180	153	550	101,1
	200	195	400	110	430	285	360	36	12	650	60	3	210,0	275	215	650	145,0

5.4. Rückschlagventil Typ: RSV16 PN 250- PN 320

Produktmerkmale

- Federbelastetes Rückschlagventil
- Metallisch dichtend
- Flanschanschluss nach EN 1092-1
- Anschweissenden nach EN 12627
- Flanschbaulänge nach EN 558 Grundreihe: 92
- Druckprüfung nach EN 12266- 1
- Abnahmeprüfzeugnis nach EN 10204- 3.1



DN15 – DN40

DN50 – DN200

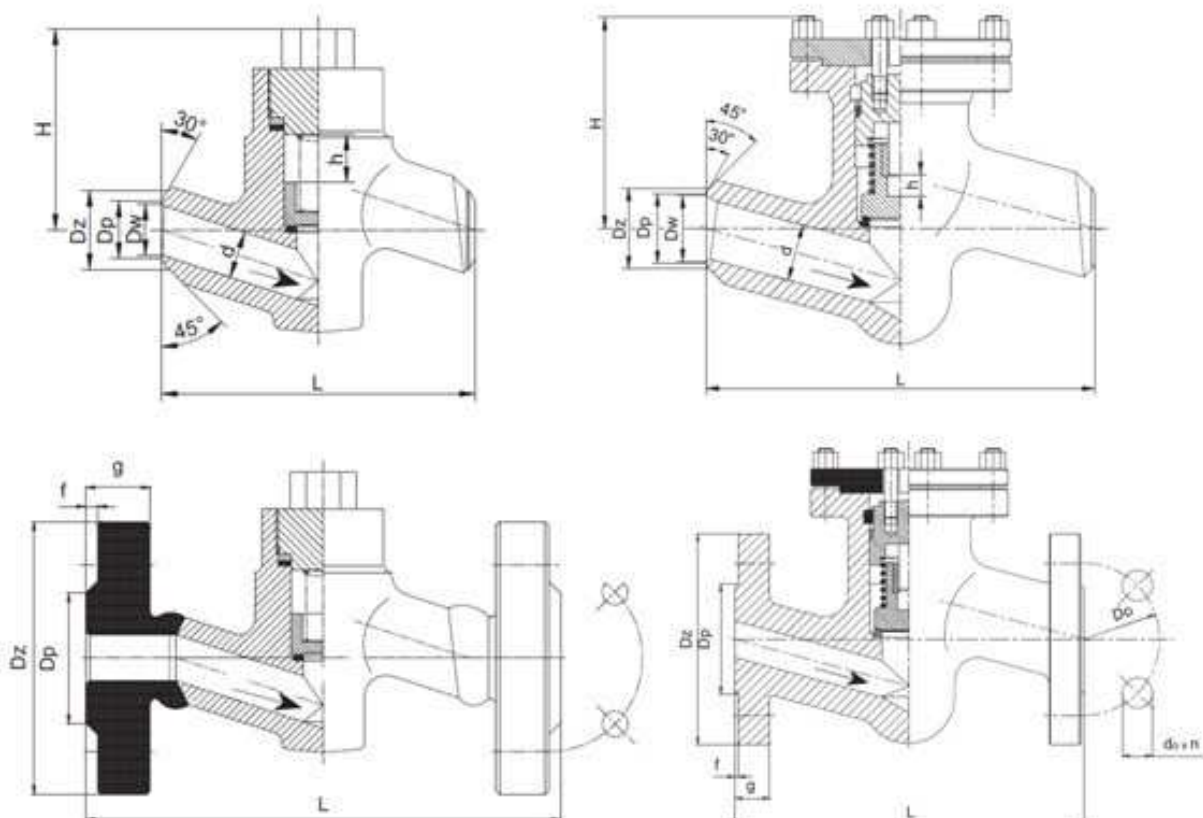

Bezeichnung	Material PN 250 - PN 320				
	T _{max} 450 °C	T _{max} 530 °C	T _{max} 560 °C	T _{max} 600 °C	T _{max} 570 °C
Gehäuse	P250GH	16Mo3	13CrMo4-5	10CrMo9-10	14MoV6-3
Gehäusedeckel DN15- DN25	(1.0460)	(1.5415)	(1.7335)	(1.7380)	(1.7715)
Gehäusedeckel ab DN 32	P265GH (1.0425)				
Gehäusesitz	X15CrNiMn18-8 (1.4370) oder Stellite 6				
Kegel	X20Cr13 (1.4021), P250GH (1.0460)				
Kegelsitz	X15CrNiMn18-8 (1.4370), Stellite 6				
Rückstellfeder	51CrMoV4 (1.2241)				
Dichtung	Graphit+ Edelstahl				

PN	DN	d	H	h	Flanschanschluss									Anschweißenden				
					Dz	Dp	Do	do	n	L	g	f	kg	Dz	Dp	Dw	L	kg
250 320	15	14	235	15	130	45	90	18	4	230	26	2	8,7	28	19	16,0	160	4,0
	20	20	240	15	150	58	105	22	4	260	30	2	11,3	34	26,5	23,5	160	4,0
	25	24	240	15	150/160*	68	105/115*	22	4	260	34	2	13,3	40	29	26,0	160	4,0
	32	-	-	-	-	-	-	-	-	-	-	-	-	44,5	36	33,3	300	15,0
	40	38	365	27	180/195*	88	135/145*	26	4	300	34/38*	3	30,2	54	45	41,4	300	15,0
	50	48	365	27	200/210*	102	150/160*	26	8	350	38/42*	3	32,0	72	65	61,0	300	15,0
	65	62	450	30	230/255*	122	180/200*	30	8	400	42/51*	3	57,8	90	71	68,0	340	26,0
	80	76	580	40	255/275*	138	200/220*	30	8	450	46/55*	3	93,0	115	90	86,0	380	55,0
	100	92	620	55	300/335*	162	235/265*	36	8	520	54/65*	3	138,5	133	109	101,0	430	71,0
	125	112	670	65	340/380*	188	275/310*	36	12	600	60/75*	3	186,9	159	141	124,0	500	91,0

* gültig für PN 320

5.5. Rückschlagklappe Typ: RSK10 PN 63 – PN 320

Produktmerkmale

- Eigengewicht gesteuerte Rückschlagklappe
- Klappenwelle innenliegend
- Einbaulage horizontal und vertikal (unter Beachtung des Richtungspfeils am Armaturengehäuse)
- Flanschanschluss nach EN 1092-1, GOST 12815-80
- Anschweissenden nach EN 12627
- Flanschbaulänge nach EN 558 Grundreihe: 2 (PN 63 – PN 160)
Grundreihe 92 (PN 250 – PN 320)
- Druckprüfung nach EN 12266- 1
- Abnahmeprüfzeugnis nach EN 10204- 3.1
- Optional mit Bypass erhältlich

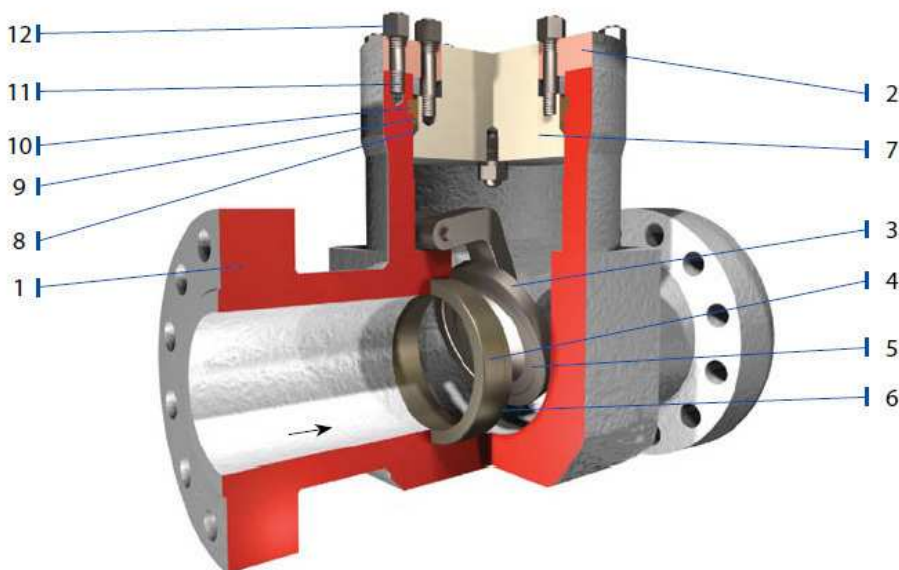

Position	Bezeichnung
1	Gehäuse
2	Gehäusedeckel
3	Klappe
4	Gehäusesitz
5	Klappensitzring
6	Gehäusesitzring
7	Verschlussdeckel
8	Dichtung
9	Ring
10	Segmentstützring
11	Schrauben
12	Muttern

Bezeichnung	Material					
	T _{max} 450 °C	T _{max} 530 °C	T _{max} 560 °C	T _{max} 570 °C	T _{max} 600 °C	T _{max} 650 °C
Gehäuse	P250GH (1.0460)	16Mo3 (1.5415)	13CrMo4-5 (1.7335)	14MoV6-3 (1.7715)	10CrMo9-10 (1.7380)	X10CrMoVNb9-1 (1.4903)
Gehäusedeckel						
Klappe						
Gehäusesitz	Stellite 12					
Klappensitz	Stellite 6					
Dichtung	Graphit +SS bei PN 63 und PN 100/ Graphit bei PN 160, PN 250 und PN 320					

PN63 – PN100

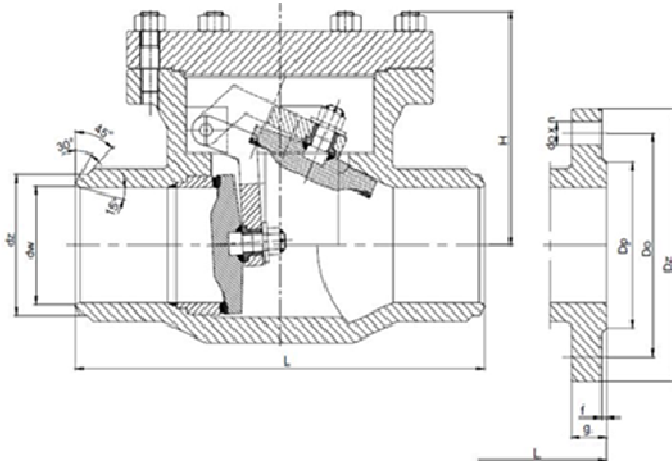

PN160– PN320

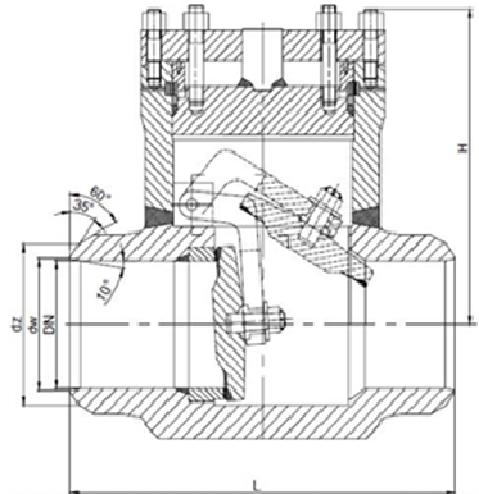

PN 63														
DN	H	Flanschanschluss									Anschweissenden			
		Dz	Dp	Do	do	n	L	g	f	kg	dz	dw	L	kg
50	170	180	102	135	22	4	300	26	3	18,0	62	54	250	12,0
65	190	205	122	160	22	8	340	26	3	25,0	77	69	290	17,0
80	205	215	138	170	22	8	380	28	3	32,0	91	81	310	22,0
100	220	250	162	200	26	8	430	30	3	45,0	117	105	350	33,0
125	254	295	188	240	30	8	500	34	3	68,0	144	128	400	50,0
150	305	345	218	280	33	8	550	36	3	100,0	172	155	450	80,0
200	406	415	285	345	36	12	650	42	3	153,0	223	203	550	105,0
250	508	470	345	400	36	12	775	46	3	248,0	278	253	650	200,0

PN 100														
DN	H	Flanschanschluss									Anschweissenden			
		Dz	Dp	Do	do	n	L	g	f	kg	dz	dw	L	kg
50	170	195	102	145	26	4	300	28	3	20,7	62	52	250	13,2
65	190	220	122	170	26	8	340	30	3	28,8	77	66	290	18,7
80	205	230	138	180	26	8	380	32	3	36,8	91	78	310	24,2
100	220	265	162	210	30	8	430	36	3	51,8	117	101	350	36,3
125	254	315	188	250	33	8	500	40	3	78,2	144	124	400	55,0
150	305	355	218	290	33	12	550	44	3	115,0	172	155	450	88,8
200	406	430	285	360	36	12	650	52	3	176	223	196	550	115,5
250	508	505	345	430	39	12	775	60	3	285,2	278	244	650	220,0

PN160														
DN	H	Flanschanschluss									Anschweissenden			
		Dz	Dp	Do	do	n	L	g	f	kg	dz	dw	L	kg
50	220	195	102	145	30	4	300	30	3	30,8	62	52	300	20,0
65	240	220	122	170	26	8	360	34	3	41,1	77	62	360	26,0
80	255	230	138	180	26	8	390	36	3	88,3	91	73	390	75,0
100	280	265	162	210	30	8	450	40	3	136,4	117	94	450	110,0
125	314	315	188	250	33	8	525	44	3	200,1	144	116	525	170,0
150	365	355	218	290	33	12	600	50	3	249,9	172	151	600	200,0
200	485	430	285	360	36	12	750	60	3	582,0	223	204	750	505,0
250	590	515	345	430	42	12	900	68	3	970,0	278	248	900	870,0
300	700	585	410	500	42	16	105	78	4	1466,	329	298	105	1320,0

PN 250														
DN	H	Flanschanschluss									Anschweissenden			
		Dz	Dp	Do	do	n	L	g	f	kg	dz	dw	L	kg
50	220	200	102	150	26	8	350	42	3	33,9	62	45	350	22,0
65	240	230	122	180	26	8	400	51	3	45,2	77	57,5	400	28,6
80	255	255	138	200	30	8	450	55	3	97,1	91	65,5	450	82,5
100	280	300	162	235	33	8	520	65	3	150,0	117	87,5	520	121,0
125	315	340	188	275	33	12	600	75	3	220,1	144	106,5	600	187,0
150	365	390	218	320	36	12	700	84	3	274,9	172	130,5	700	220,0
200	485	485	285	400	42	12	800	103	3	640,2	223	172	800	555,5
250	590	585	345	490	48	16	900	125	3	1067,	278	212,5	900	957,0
300	700	690	410	590	52	16	105	150	4	1612,	329	285,5	105	1452,0

PN 320					
Anschweissenden					
DN	dz	dw	L	H	kg
50	62	43,5	350	220	37,3
65	89	65,5	400	240	49,7
80	108	77,5	450	255	106,8
100	133	100	520	280	165,0
125	159	117,5	600	314	242,1
150	194	141,5	700	365	302,4
200	245	177	800	485	704,2
250	324	248,5	900	590	1174,5
300	356	271	1050	700	1773,9

5.6. Druck- Temperaturtabellen

PN 63																			
Gehäusematerial	maximal zulässige Temperatur [°C]																		
	20 °C	100 °C	150 °C	200 °C	250 °C	300 °C	350 °C	400 °C	450 °C	480 °C	500 °C	520 °C	530 °C	540 °C	560 °C	570 °C	580 °C	590 °C	600 °C
	maximaler Betriebsdruck [bar]																		
P250GH (1.0460)	63,0	58,5	55,5	52,5	48,0	43,5	40,5	37,5	20,7	20,7									
16Mo3 (1.5415)	63,0	63,0	63,0	63,0	61,5	54,0	51,0	48,0	46,5	35,3	27,9	17,7	14,1						
13CrMo4-5 (1.7335)	63,0	63,0	63,0	63,0	63,0	62,7	60,0	57,0	54,0	46,2	41,1	28,2	23,4	18,3	12,0	9,9			
14MoV6-3 (1.7715)	63,0	63,0	63,0	63,0	63,0	63,0	63,0	62,7	60,9	60,5	57,9	44,7	39,3	33,9	25,8	21,9			
10CrMo9-10 (1.7380)	63,0	63,0	63,0	63,0	63,0	63,0	61,5	58,5	55,5	46,5	40,5	30,9	27,0	23,4	17,4	15,3	13,2	14,4	10,2
GP240GH (1.0619)	63,0	58,5	55,5	52,5	48,0	43,5	40,5	37,5	20,7										
G20Mo5 (1.5419)	63,0	63,0	63,0	63,0	61,5	54,0	51,0	48,0	46,5	35,3	27,9	17,7	14,1						
G17CrMo5-5 (1.7357)	63,0	63,0	63,0	63,0	63,0	62,7	60,0	57,0	54,0	46,2	41,1	28,2	23,4	18,3	12,0				

PN 100																			
Gehäusematerial	maximal zulässige Temperatur [°C]																		
	20 °C	100 °C	150 °C	200 °C	250 °C	300 °C	350 °C	400 °C	450 °C	480 °C	500 °C	520 °C	530 °C	540 °C	560 °C	570 °C	580 °C	590 °C	600 °C
	maximaler Betriebsdruck [bar]																		
P250GH (1.0460)	100,0	92,8	88,0	83,3	76,1	69,0	64,2	59,5	32,8										
16Mo3 (1.5415)	100,0	100,0	100,0	100,0	97,6	85,7	80,9	76,1	73,8	56,0	44,2	28,0	22,3						
13CrMo4-5 (1.7335)	100,0	100,0	100,0	100,0	100,0	99,5	95,2	90,4	85,7	73,4	65,2	44,7	37,1	29,0	19,0	15,7			
14MoV6-3 (1.7715)	100,0	100,0	100,0	100,0	100,0	100,0	100,0	99,5	96,7	96,0	91,9	71,0	62,4	53,8	41,0	34,8			
10CrMo9-10 (1.7380)	100,0	100,0	100,0	100,0	100,0	100,0	97,6	92,8	88,0	73,8	64,2	49,0	42,8	37,1	27,6	24,2	20,9	18,0	16,1
GP240GH (1.0619)	100,0	92,8	88,0	83,3	76,1	69,0	64,2	59,5	32,8										
G20Mo5 (1.5419)	100,0	100,0	100,0	100,0	97,6	85,7	80,9	76,1	73,8	56,0	44,2	28,0	22,3						
G17CrMo5-5 (1.7357)	100,0	100,0	100,0	100,0	100,0	99,5	95,2	90,4	85,7	73,4	65,2	44,7	37,1	29,0	19,0				

PN 160																			
Gehäusematerial	maximal zulässige Temperatur [°C]																		
	20 °C	100 °C	150 °C	200 °C	250 °C	300 °C	350 °C	400 °C	450 °C	480 °C	500 °C	520 °C	530 °C	540 °C	560 °C	570 °C	580 °C	590 °C	600 °C
	maximaler Betriebsdruck [bar]																		
P250GH (1.0460)	160,0	148,5	140,9	133,3	121,9	110,4	102,8	95,2	52,5										
16Mo3 (1.5415)	160,0	160,0	160,0	160,0	156,1	137,1	129,5	121,9	118,0	98,7	70,8	44,9	35,8						
13CrMo4-5 (1.7335)	160,0	160,0	160,0	160,0	160,0	159,2	152,3	144,7	137,1	117,4	104,3	71,6	59,4	46,4	30,4	25,1			
14MoV6-3 (1.7715)	160,0	160,0	160,0	160,0	160,0	160,0	160,0	159,2	154,7	153,5	147,0	113,5	99,8	86,1	56,5	55,6			
10CrMo9-10 (1.7380)	160,0	160,0	160,0	160,0	160,0	160,0	156,1	148,5	140,9	118,0	102,8	78,4	68,5	59,4	44,1	38,8	33,5	28,9	25,9
GP240GH (1.0619)	160,0	148,5	140,9	133,3	121,9	110,4	102,8	95,2	52,5										
G20Mo5 (1.5419)	160,0	160,0	160,0	160,0	156,1	137,1	129,5	121,9	118,0	98,7	70,8	44,9	35,8						
G17CrMo5-5 (1.7357)	160,0	160,0	160,0	160,0	160,0	159,2	152,3	144,7	137,1	117,4	104,3	71,6	59,4	46,4	30,4	25,1			
X10CrMoVnb9-1 (1.4903)	160,0	160,0	160,0	160,0	160,0	160,0	160,0	160,0	160,0	160,0	160,0	153,0	139,4	114,3	102,1	91,4	80,8		71,6

PN 250																			
Gehäusematerial	maximal zulässige Temperatur [°C]																		
	20 °C	100 °C	150 °C	200 °C	250 °C	300 °C	350 °C	400 °C	450 °C	480 °C	500 °C	520 °C	530 °C	540 °C	560 °C	570 °C	580 °C	590 °C	600 °C
	maximaler Betriebsdruck [bar]																		
P250GH (1.0460)	250,0	232,1	220,2	208,3	199,4	172,6	160,7	148,8	82,1										
16Mo3 (1.5415)	250,0	250,0	250,0	250,0	244,0	214,2	202,3	190,4	184,5	140,2	110,7	70,2	55,9						
13CrMo4-5 (1.7335)	250,0	250,0	250,0	250,0	250,0	248,8	238,0	226,1	214,2	183,5	163,0	111,9	92,8	72,6	47,6	39,2			
14MoV6-3 (1.7715)	250,0	250,0	250,0	250,0	250,0	250,0	250,0	248,8	241,7	239,9	229,8	177,4	156,0	134,5	102,4	86,9			
10CrMo9-10 (1.7380)	250,0	250,0	250,0	250,0	250,0	250,0	244,0	232,1	220,2	184,5	160,7	122,6	107,1	92,8	69,0	60,7	52,3	45,2	40,4
X10CrMoVnb9-1 (1.4903)	250,0	250,0	250,0	250,0	250,0	250,0	250,0	250,0	250,0	250,0	250,0	239,0	218,0	179,0	160,0	142,9	126,2		111,9

Druck- Temperaturtabellen

PN 320																			
Gehäusematerial	maximal zulässige Temperatur [°C]																		
	20 °C	100 °C	150 °C	200 °C	250 °C	300 °C	350 °C	400 °C	450 °C	480 °C	500 °C	520 °C	530 °C	540 °C	560 °C	570 °C	580 °C	590 °C	600 °C
maximaler Betriebsdruck [bar]																			
P250GH (1.0460)	320,0	297,1	281,9	266,6	243,8	220,9	205,7	190,4	105,1										
16Mo3 (1.5415)	320,0	320,0	320,0	320,0	312,3	274,2	259,0	243,8	236,1	179,5	141,7	89,9	71,6						
13CrMo4-5 (1.7335)	320,0	320,0	320,0	320,0	320,0	318,4	304,7	289,5	274,2	234,9	208,7	143,2	118,8	92,9	60,9	50,2			
14MoV6-3 (1.7715)	320,0	320,0	320,0	320,0	320,0	320,0	320,0	318,5	309,3	307,0	294,1	227,0	199,6	172,2	131,0	111,2			
10CrMo9-10 (1.7380)	320,0	320,0	320,0	320,0	320,0	320,0	312,3	297,1	281,9	236,1	205,7	156,9	137,1	118,8	88,3	77,7	67,0	57,9	51,8
X10CrMoVnb9-1 (1.4903)	320,0	320,0	320,0	320,0	320,0	320,0	320,0	320,0	320,0	320,0	320,0	320,0	306,0	279,0	229,0	204,0	183,0	162,0	143,2

PN 400																			
Gehäusematerial	maximal zulässige Temperatur [°C]																		
	20 °C	100 °C	150 °C	200 °C	250 °C	300 °C	350 °C	400 °C	450 °C	480 °C	500 °C	520 °C	530 °C	540 °C	560 °C	570 °C	580 °C	590 °C	600 °C
maximaler Betriebsdruck [bar]																			
P250GH (1.0460)	400,0	400,0	400,0	400,0	390,4	342,8	323,8	304,8	295,1	224,4	177,1	112,4	89,5						
16Mo3 (1.5415)	400,0	400,0	400,0	400,0	400,0	398,0	380,9	361,9	342,8	293,6	260,9	179,0	148,5	116,1	76,1	62,7			
13CrMo4-5 (1.7335)	400,0	400,0	400,0	400,0	400,0	400,0	400,0	398,1	386,7	383,8	367,6	283,8	249,5	215,2	163,8	139,0			
14MoV6-3 (1.7715)	400,0	400,0	400,0	400,0	400,0	400,0	400,0	398,1	386,7	383,8	367,6	283,8	249,5	215,2	163,8	139,0			
10CrMo9-10 (1.7380)	400,0	400,0	400,0	400,0	400,0	400,0	390,4	371,4	352,4	295,1	257,1	196,1	171,4	148,5	110,4	97,1	83,8	72,4	64,8
X10CrMoVnb9-1 (1.4903)	400,0	400,0	400,0	400,0	400,0	400,0	400,0	400,0	400,0	400,0	400,0	400,0	383,0	349,0	286,0	255,0	229,0	202,0	179,0



Ventiltechnik

Bei Fragen oder sonstigen Anregungen wenden Sie sich bitte an das PSA-Ventiltechnik-Team unter:

Kontakt:

PSA-Ventiltechnik OG

Attemsgasse 45/1/7

A-1220 Wien

Austria

Homepage: www.psa-ventiltechnik.at

Email: office@psa-ventiltechnik.at

Tel. & Fax: +43 (0)1 20 21 985

**Der gesamte Inhalt dieses Produktkataloges ist vorbehaltlich technischer
Änderungen und Irrtümer.**